

面板安装开孔图
Panel cut out

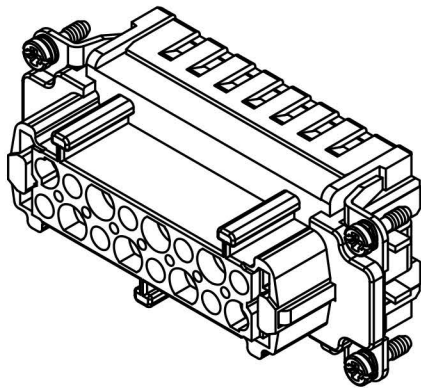

技术参数:

插芯:

- 插针数: 16+PE
 - 额定电流: 16A
 - 额定电压: 500V
 - 额定脉冲电压: 6kV
 - 污染等级: 3
 - 依据UL/CSA的额定电压: 600V
 - 绝缘阻抗: $>10^{10}\Omega$
 - 材料: 聚碳酸酯
 - 颜色: RAL 7032 (浅灰色)
 - 温度范围: $-40^{\circ}\text{C} - +125^{\circ}\text{C}$
 - 依据UL 94的阻燃等级: V0
 - 可插拔次数: >500
- 插针:
- 接线方式: 冷压连接
 - 材料: 铜合金
 - 表面处理:
 - 镀银
 - 镀金
 - 接触电阻: $<1\text{m}\Omega$
 - 线径范围: $0.14-4.0\text{mm}^2(26-12\text{ AWG})$
 - 剥线长度: 7.5mm
 - 工具:
 - 冷压钳: TL02G
 - 退针器: TL01

Technical specification:

Insters:

- No. of contact: 16+PE
- Rated current: 16A
- Rated voltage: 500V
- Rated impulse voltage: 6kV
- Pollution degree: 3
- Rated voltage acc.to UL/CSA: 600V
- Insulation resistance: $>10^{10}\Omega$
- Material: polycarbonate
- Colour: RAL 7032(light grey)
- Temperature range: $-40^{\circ}\text{C} - +125^{\circ}\text{C}$
- Flammability acc.to UL 94: V0
- Mating cycles: >500

Contacts:

- Terminal: crimp terminal
- Material: copper alloy
- Surface:
 - hard-silver plated
 - hard-gold plated
- Contact resistance: $<1\text{m}\Omega$
- Wire gauge: $0.14-4.0\text{mm}^2(26-12\text{ AWG})$
- Stripping length: 7.5mm
- Tools:
 - Crimp contact tool: TL02G
 - Contact removal tool: TL01

					表面处理 Finish	-			图号 Drawing No.	-
					材料 Material	-			产品代号 Part Code	HE-016-FC
标记 Mark	处数 Number	变更描述/Description			签名 Signature	日期 Date			产品料号 Part No.	2040164201
	姓名/Name	日期/Date		姓名/Name	日期/Date	比例 Scale	版本 REV.	重量 Weight	数量 Qty.	产品名称 Part Name
绘图 Drawn		18.10.2010	标准化 Stand.	-	-	1:1	V1.0	60.2g	-	-
审核 Checked		18.10.2010								
工艺 Process	-	-	批准 Approved		18.10.2010	All Dimensions in mm Original Size DIN A 4			浙江西霸士电气有限公司	